

telguard®



Bespoke

The TelGuard Bespoke product is a range of telephone based entry systems that are individually tailored to the requirements of the customer. The Bespoke is designed to suit smaller projects of up to 14 houses/apartments/offices. As with all TelGuard audio products, there are only three connections required; an analogue telephone exchange line socket or analogue extension of a telephone system, a 230v 5A power source for the 12v power supply unit and a multicore connection to the equipment to be controlled.

The Bespoke is available with 1-14 stainless steel call buttons in addition to trade and assistance buttons. A backlit coded entry keypad is also available, operated by entering a 4 digit code.

Where there is a requirement for video entry, a camera may be mounted in the call panel and the picture is either modulated onto a TV aerial amplifier for viewing on a normal television or directly linked to a monitor. A proximity reader may also be panel mounted for access control. These items operate independently to the TelGuard unit.

Basic System Operation

A visitor presses the required number on the panel by using the buttons. A phone call is then made to the destination. On answering the call on

the telephone two way speech may take place. After confirming the identity of the visitor, the '#' key is pressed on the telephone and a tone will be heard to indicate operation of the command to open the door/gate/barrier. If any of the other 4 relays require activation, the user presses a digit first followed by '#' eg '2#'. TelGuard is able to be operated from a DECT (Digital Enhanced Cordless Telecommunications) or mobile phone, making communication with the entrance possible even when out of the property, or of site.

Standard Features

- 1 – 14 call button ability
- Button activation tone
- Five relays
- Relay activation tone
- Secondary number search facility*
- Full duplex speech
- 316 marine grade stainless steel fascia
- Concierge divert
- Vandal resistant
- Slave panel facility

** Reliant on detecting local exchange settings.
Not compatible with PBX systems.*

*** Use of this facility removes operation of other relays.*

Optional Features

- Acoustic call progress indication 'ENTRANCE CALLING', 'ENTER'
- Door panel call alert to destination on receipt of call 'ENTRANCE CALLING'
- Backlit coded entry keypad
- Backlit buttons
- Stainless steel Piezo buttons
- Backlit Piezo buttons
- Monochrome or colour camera
- Panel mounted proximity reader
- Wheelchair user assistance button
- Concierge button
- Brass/Powder coated finish
- Trade facility

GSM VERSION
NOW AVAILABLE

Unit 2/3 The Old Stables Ockley Court Farm Coles Lane Ockley Surrey RH5 5LS
Tel: +44 (0)1306 710120 Fax: +44 (0)1306 713769
Email: sales@telguard.co.uk

www.dooreentry.co.uk

TelGuard Bespoke

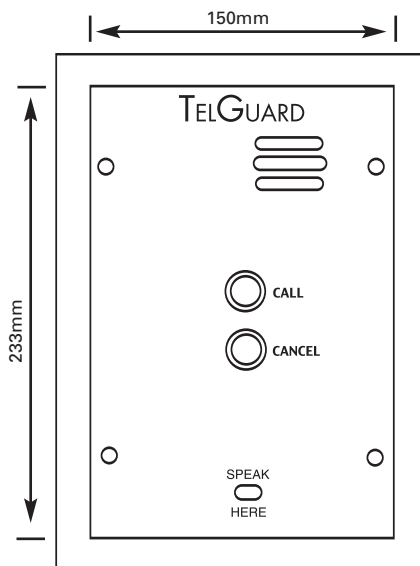
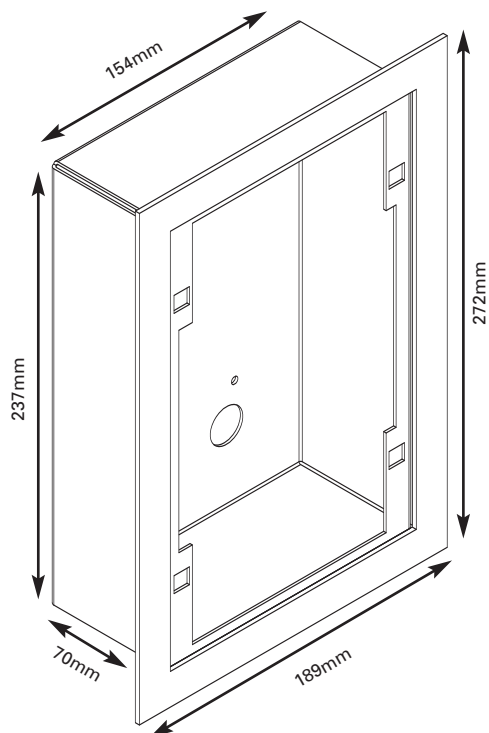

Bespoke panel

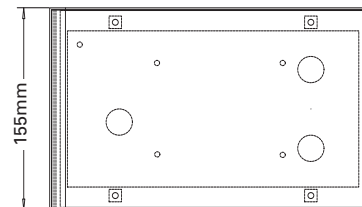
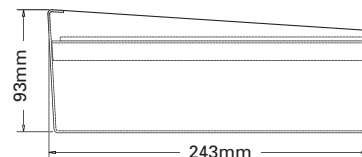

Surface back box

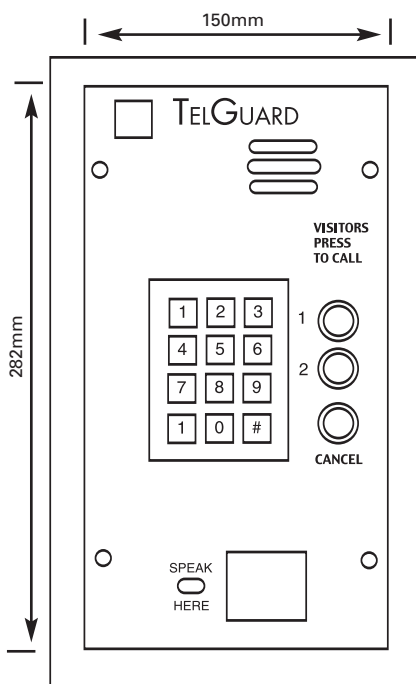
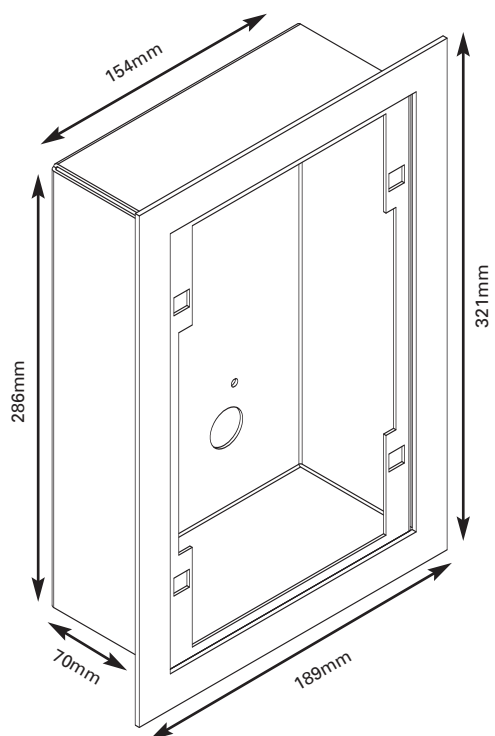

Bespoke with coded entry keypad, camera and proximity

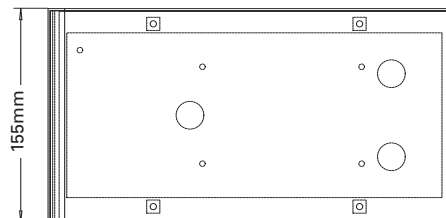
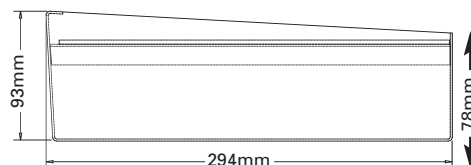

Surface back box

Flush back box

Specification

- Power supply: 12v 1A DC (supplied with system)
- Power consumption: 400 mA @12v
- Telephone connection: standard analogue 'BT' type telephone socket or analogue extension from a PABX
- Telephone type: standard tone generating telephone, DECT or mobile. All telephones must have a '#' key and be able to tone dial from all keys on an incoming call
- Secondary number search facility: activated on engaged tone or if call is not answered within a preset number of rings.*
- Programming: actioned remotely from TelGuard offices by trained staff.

- Operating relays: five – pulsing/latching n/o n/c
- Operating commands:
 - Relay 1 = # or single digit 0 – 9**
 - Relay 2/3/4/5 = 1 – 4 digits then #
- Call number sequence: 1 – 4 digits
- Relay contact ratings:
 - Relay 1 – 2.5A @12/24v ac/dc
 - Relay 2,3,4,5 -100mA @12/24v ac/dc
 - Clean contacts
- Relay activation time: 1 – 9 seconds