

EA TRIPOD

The EA Tripod turnstile is a robust and reliable model from our tripod series. This model efficiently controls the pedestrian entrance of the busiest areas. The EA Tripod turnstile design, with its choice of housing finishes will perfectly fit a broad variety of buildings and facilities that need pedestrian control. Succinct design and the high quality materials used in manufacture, ensure a smooth and highly reliable operation. In the case of an emergency, the EA Tripod turnstile has a "drop arm" function to allow free movement and is also available with an optional battery backup during power outages.

EA Tripod Twin is also available with double sided tripods.



When power goes OFF both directions are free.

Controlled by:  Access control system  Push button

TECHNICAL SPECS:

Width, mm	750
Length, mm	1000
Height, mm	1000
Weight, kg (not more)	78
Mechanism	Motorized
Standard housing	Brushed AISI 304
Available housing	Brushed SS AISI 316 Polished SS AISI 304 Polished SS AISI 316 Powder coated RAL

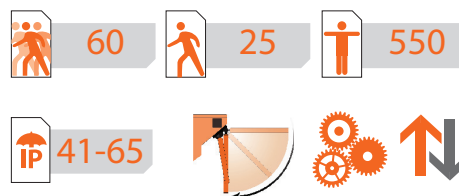

ELECTRICAL SPECS:

- Voltage:
 - from the AC (100-240)V, 50/60Hz;
 - from a DC source 12 V.
- Maximum power consumption 50 W per pass.

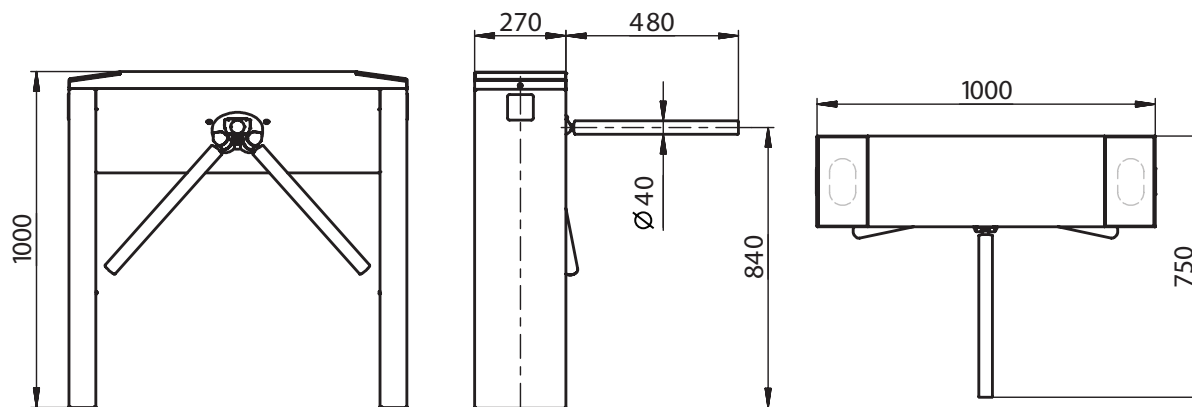

EA Group (UK) Limited, Units 20-21, Bookham Industrial Park, Church Road, Bookham, Surrey, KT23 3EU

Telephone: 01372 459536 Fax: 01372 454778 Website: www.ea-group.co.uk

PART OF THE ELECTRO AUTOMATION GROUP OF COMPANIES

REGISTERED IN ENGLAND NO. 3094251 VAT NO. 664124937

